



EMME ANTINCENDIO S.r.l.
www.emme-italia.com

18158-52

150Kg Powder WHEELED FIRE EXTINGUISHER



Note: Image is for illustrative purpose only, the product bought can has some differences

- CYLINDER
Alloy steel, epoxy polyester powder painting, Red Ral 3000.
- EXTINGUISHING AGENT
ABC powder - MAP 40 %
- PROPELLANT
Fire extinguisher pressurized at moment of use with 5kg Co2 external cylinder, complete of protection for valve.
- CAP
Brass 2".
- USE
A B C fire rating (solid materials, flammable liquids, flammable gas).
- BRACKET
Chassis on wheels, welded at the cylinder, red painting RAL3000.

150kg powder wheeled fire extinguisher, pressurized at moment of use, temperature range from -30°C to +60°C, manufactured in accordance to **EN 1866-1**, approved to European Marine Directive **MED 2014/90/EU, S.O.L.A.S.** (Safety of life at sea) '74 (2000), certified according to the directive for pressure equipment PED 2014/68/EU. Quality Product certification guaranteed by Bureau Veritas Italia. Suitable for use on fire involving electrical voltages up to 1000 V, minimum distance of 1 mt.

AVAILABLE VERSIONS

N.	CODE	DESCRIPTION
1	16158-52	150kg powder fire extinguisher, complies MED 2014/90/EU

APPROVED/CERTIFIED FIRE EXTINGUISHER:



FIRE RATING :



150Kg Powder WHEELED FIRE EXTINGUISHER

TECHNICAL SPECIFICATIONS

FIRE RATING	A IV B C
EXTINGUISHING AGENT	EPB 0351 (Q-Fire 40) Powder MAP 40 %
PROPELLANT	2,5 Kg of CO2
TEMPERATURE RANGE	-30°C +60°C
NOMINAL CHARGE	150 Kg
FULL WEIGHT	~ 210 Kg
DIMENSIONS	Height 1350 mm Width 750 mm Depth 640 mm
DISCHARGE TIME	~ 92,3 sec.
CAP TIGHTENING TORQUE	Minimum 60 Nm - Maximum 70 Nm
CYLINDER PRESSURE TEST	PT 30 bar
CYLINDER VOLUME	170 L.
SAFETY DEVICE	Set between 21 and 26 bar
CYLINDER MATERIAL	Alloy steel
EXTERNAL/INTERNAL TREATMENT	Sandblast and epoxy polyester powder painting, Red Ral 3000 colour

PACKAGING

STANDARD :
max 1 pieces on pallet 100x120x150

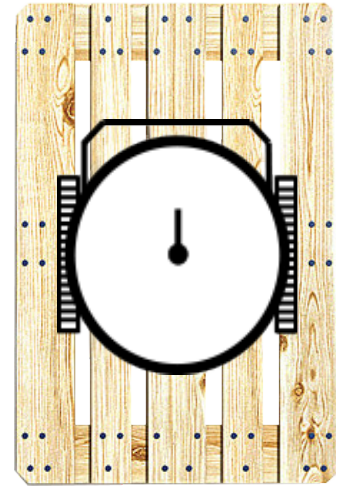

MAINTENANCE AND INSTALLATION

For outdoor or marine installation is recommended to protect the fire extinguisher with cover. Maintenance according to the norm in use in utilization country.

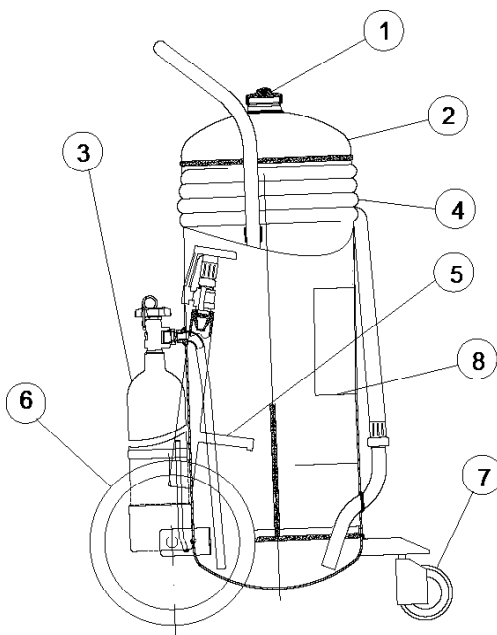

SAPARE PARTS

NUMBER	DESCRIPTION	CODE
1	Cap 2"	18463
2	Cylinder	18315
3	External cylinder CO2, complete of protection for valve	-
4	Hose	18422-1
5	Dispensing nozzle (complete of ball valve with control lever)	2181-1
6	Wheel + wheel stop (diam. 400mm)	0125
7	Front wheel	1686
8	Label	18397

EMME ANTINCENDIO S.r.l

Factory: Via del Molino, 40 – 52010 Corsalone (AR) – Italy – Tel. +39.0575.511320
Warehouse MI: Via G. Di Vittorio, 11 – 20017 Mazzo di Rho (MI) – Italy – Tel. +39.0293900399
Warehouse PD: Via Polonia, 35 - 35127 Padova (PD) - Italy - Tel. +39.049.6453824
E-mail: info@emme-italia.com – web site: www.emme-italia.com
P.IVA/ C.F. 11208251006 – R.E.A. FI-632545

File name	Code	Date	Rele.	Check	Rev.	Pag.
ds_18158-52	18158-52	23/11/17	M.R	AA	1	2