



EMME ANTINCENDIO S.r.l.

www.emme-italia.com

18118-52

100Kg Powder WHEELED FIRE EXTINGUISHER



- CYLINDER
Alloy steel, epoxy polyester powder painting, Red Ral 3000.
- EXTINGUISHING AGENT
ABC Powder
- PROPELLANT
Fire extinguisher pressurized at moment of use with 5kg Co2 external cylinder, complete of protection for valve.
- CAP
Brass 2".
- USE
A B C fire rating
(solid materials, flammable liquids, flammable gas).
- BRACKET
Chassis on wheels, welded at the cylinder, red painting RAL3000.

Note: image is for illustrative purpose only, the product purchased can have some differences

100kg powder wheeled fire extinguisher, pressurized at moment of use, temperature range from -30°C to +60°C, manufactured in accordance to **EN 1866-1**, approved to European Marine Directive **MED 2014/90/EU, S.O.L.A.S.** (Safety of life at sea) '74 (2000), certified according to the directive for pressure equipment PED 2014/68/EU. Quality Product certification guaranteed by Bureau Veritas Italia. Suitable for use on fire involving voltages up to 1000 volts.

AVAILABLE VERSIONS

N.	CODE	DESCRIPTION
1	16118-52	100kg powder fire extinguisher, complies MED 2014/90/EU

APPROVED/CERTIFIED FIRE EXTINGUISHER:



FIRE RATING :



100Kg Powder WHEELED FIRE EXTINGUISHER

TECHNICAL SPECIFICATIONS

FIRE RATING	A IV B C
EXTINGUISHING AGENT	EPB 0351 powder
PROPELLANT	External cylinder 5kg Co2
TEMPERATURE RANGE	-30°C +60°C
NOMINAL CHARGE	100 Kg
FULL WEIGHT	~ 175 Kg
DIMENSIONS	Height 1350 mm Width 560 mm Depth 540 mm
DISCHARGE TIME	62 sec.
CAP TIGHTENING TORQUE	Minimum 60 Nm - Maximum 70 Nm
CYLINDER PRESSURE TEST	PT 30 bar
CYLINDER VOLUME	102 L.
SAFETY VALVE	Set 20 and 21 bar
CYLINDER MATERIAL	Alloy steel
EXTERNAL/INTERNAL TREATMENT	Sandblast and epoxy polyestere powder painting, Red Ral 3000 colour

PACKAGING

STANDARD :
max 2 pieces on pallet 100x120x150

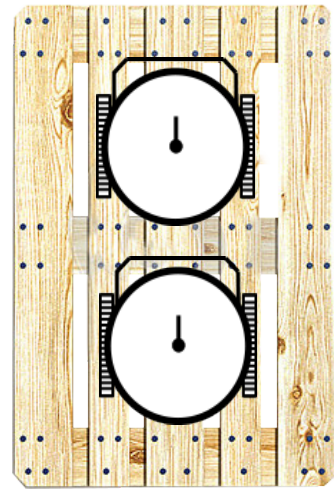

MAINTENANCE AND INSTALLATION

For outdoor or marine installation is recommended to protect the fire extinguisher with cover. Maintenance according to the norm in use in utilization country.

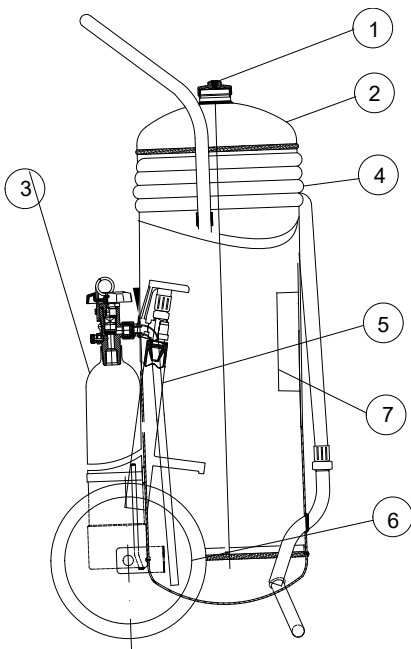

SAPARE PARTS

NUMBER	DESCRIPTION	CODE
1	Cap 2"	18463
2	Cylinder	18313
3	External cylinder Co2, complete of protection for valve	-
4	Hose	18422-1
5	Dispensing nozzle (complete of ball valve with control lever)	2181-1
6	Wheel + wheel stop (diam. 400mm)	0125
7	Label	18395
OPTIONAL	Supplement safety valve for wheeled fire extinguisher (set 23 and 27 bar)	2048
	ABC powder	0351

EMME ANTINCENDIO S.r.l

Factory: Via del Molino, 40 - 52010 Corsalone (AR) - Italy - Tel. +39.0575.511320
Warehouse MI: Via G. Di Vittorio, 11 - 20017 Mazzo di Rho (MI) - Italy - Tel. +39.0293900399
Warehouse PD: Via Polonia, 35 - 35127 Padova (PD) - Italy - Tel. +39.049.6453824
E-mail: info@emme-italia.com - web site: www.emme-italia.com
P.IVA/ C.F. 11208251006 - R.E.A. FI-632545

File name	Code	Date	Rele.	Check	Rev.	Pag.
ds_18118-52	18118-52	10/10/18	M.R		1	2