

Technical Manual



www.emme-italia.com

Via del Molino, 40 - 52010 Corsalone (AR) - Italy - info@emme-italia.com - Tel. +39.0575.511320
 Other branches in Italy : Milano - Padova - Roma - Palermo - Cagliari - P.IVA/ C.F. 11208251006 - R.E.A. AR-159122

18508 : Wheeled Fire Extinguisher, 50 Kg ABC Powder



- **CYLINDER**
In high-strength alloy steel, external powder painting Red Ral 3000.
- **EXTINGUISHING AGENT**
ABC powder - MAP 20% .
- **PROPELLANT**
Dehumidified air or Nitrogen (N₂).
- **VALVE**
2"-F , brass body, lever with red painting Ral 3000.
- **USE**
A B C fire rating
(solid materials, flammable liquids, flammable gas.
- **BRACKET**
Chassis on wheels, welded at the cylinder, red painting Ral 3000.

Note: image is for illustrative purpose only, the product purchased can has some difference

50 Kg powder wheeled fire extinguisher, temperature range from -30°C to +60°C, manufactured in accordance to **UNI EN 1866-1 (D.M. 6.3.92)**, certified according to the directive for pressure equipment PED 2014/68/EU. Quality Product certification guaranteed by Bureau Veritas Italia. Suitable for use on fire involving electrical voltages up to 1'000 V, at a minimum distance of 1 m.

APPROVED/CERTIFIED FIRE EXTINGUISHER:



FIRE RATING :



REPRODUCTION IS PROHIBITED

File name	Type of document	Fire Extinguisher Model	Date	Rele.	Check	Rev.	Pag.
18508_technical manual	technical manual	18508	23/10/2024	M.R		2	1/3

18508 : Wheeled Fire Extinguisher, 50 Kg ABC Powder

- **INSTALLATION** The installation and the control and/or recovery operations of fire extinguisher must be performed by qualified technician and in accordance to current regulations on the matter.
- **USE** The technician will carry out annual inspection for check the internal pressure
- **MAINTENANCE** and after all other steps planned during the fire extinguisher useful life.

Any tampering or operation performed by unqualified technician, void the product warranty.

If possible, is recommended to place fire extinguisher in a dry place, protected from atmospheric agents.

For installation, use and maintenance follow as indicated in file : CPP_1_ENG

TECHNICAL SPECIFICATIONS

FIRE RATING	A III B C
EXTINGUISHING AGENT	ABC powder - MAP 20 % EPW 18462 (ABC Favorit Tertia - Rühl)
PROPELLANT	Dehumidified air or Nitrogen (N ₂), 15 Bar at 20°C
TEMPERATURE RANGE	-30°C / +60°C
NOMINAL CHARGE	50 Kg
FULL WEIGHT	~ 79,0 Kg
DIMENSIONS	Height 1100 +/- 10 mm; Width 490 +/- 10 mm Depth 500 +/- 15 mm
DISCHARGE TIME	~ 50,7 seconds
CYLINDER PRESSURE TEST	PT 30 bar
CYLINDER VOLUME	62 L
SAFETY DEVICE	Set between 21 and 26 bar
CYLINDER MATERIAL	Alloy steel
TREATMENT	Outside : Sandblast and powder painting Ral 3000

PACKAGING

(Note: quantities and measurements are indicative and can be subject at changes)

STANDARD
Maximum nr. 6 pieces for pallet
Pallet dimensions 100x120x135(h) cm

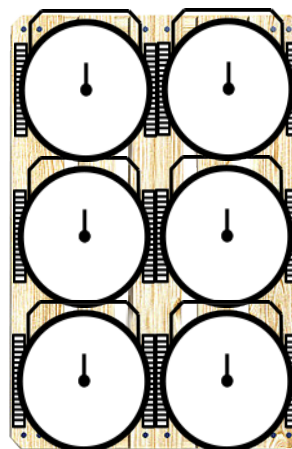

TRANSPORT DISPOSAL

Land transport : Exemption for the purposes of ADR disposal 594
Ship Transport : IMDG Code - UN 1044 class 2.2 Fire Extinguishers

File name	Type of document	Fire Extinguisher Model	Date	Rele.	Check	Rev.	Pag.
18508_technical manual	technical manual	18508	23/10/2024	M.R		2	2/3

18508 : Wheeled Fire Extinguisher, 50 Kg ABC Powder

COMPONENTS AND SPARE PARTS LIST

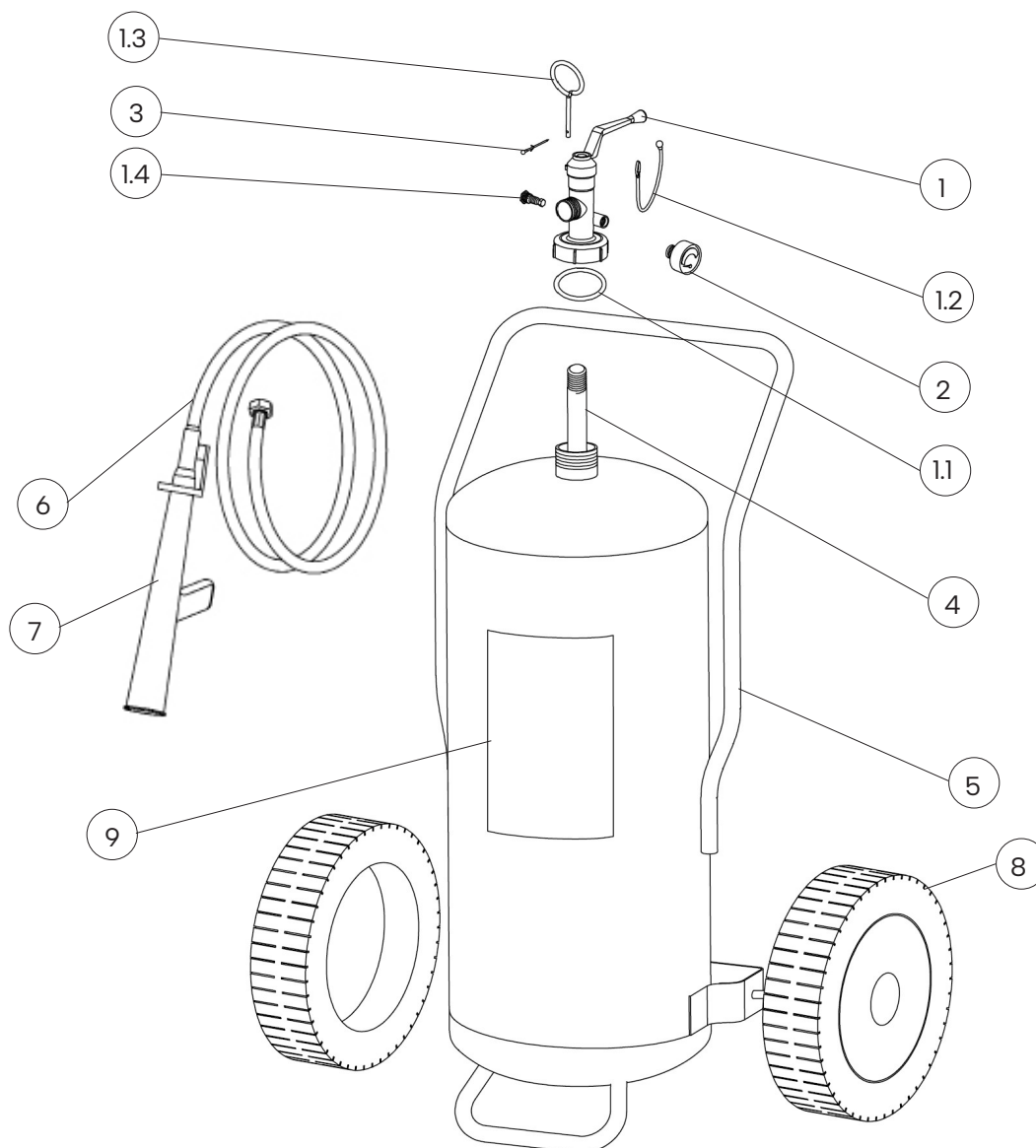

NUM.	DESCRIPTION	CODE
1	Valve 2"-F	0214R
1.1	O-ring valve	0203
1.2	Temper seal	0286
1.3	Safety pin	0283R
1.4	Safety device	0263R
2	Pressure gauge	0271-1
3	Safety pin seal	0285
4	PVC dip tube	0162
5	Cylinder	18309

NUM.	DESCRIPTION	CODE
6	Hose	18421
7	Dispensing lance (complete of ball valve with control lever)	2181
8	Wheel + wheel stop (diam. 300mm)	0124
9	Label	18359-1

The spare part at number 1 includes already all others components from 1.1 to 1.4

File name	Type of document	Fire Extinguisher Model	Date	Rele.	Check	Rev.	Pag.
18508_technical manual	technical manual	18508	23/10/2024	M.R		2	3/3