

Technical Manual



www.emme-italia.com

Via del Molino, 40 - 52010 Corsalone (AR) - Italy - info@emme-italia.com - Tel. +39.0575.511320

Other branches in Italy: Milano - Padova - Roma - Palermo - Cagliari - P.IVA/ C.F. 11208251006 - R.E.A. AR-159122

19118-52 - Lombardia 18264 : Wheeled Fire Extinguisher, 100 L Foam



- **CYLINDER**
Stainless steel AISI 304, powder painting, Red Ral 3000.
- **EXTINGUISHING AGENT**
Water based foam.
- **PROPELLANT**
Auxiliary pressure.
Fire extinguisher pressurized at moment of use with CO₂.
- **CAP**
2"-F, brass.
- **USE**
A B fire rating
(solid materials, flammable liquids).
- **BRACKET**
Chassis on wheels, welded at the cylinder, red painting Ral 3000.

REPRODUCTION IS PROHIBITED

Note: image is for illustrative purpose only, the product purchased can have some differences

100 L foam wheeled fire extinguisher, pressurized at moment of use, temperature range from +5°C to +60°C, manufactured in accordance to **UNI EN 1866-1**, approved Marine Equipment Directive **MED 2014/90/EU**, certified according to the directive for pressure equipment **PED 2014/68/EU**.
Quality Product certification guaranteed by Bureau Veritas Italia.
Suitable for use on fire involving electrical voltages up to 1'000 V, at a distance of 1 meter.

APPROVED\CERTIFIED FIRE EXTINGUISHER:



FIRE RATING :



File name	Type of document	Fire Extinguisher Model	Date	Rel.	Check	Rev.	Pag.
19118-52_Technical Manual	Technical Manual	19118-52	22/10/2024	M.R		2	1/3

19118-52 – Lombardia 18264 : Wheeled Fire Extinguisher, 100 L Foam

- **INSTALLATION**
- **USE**
- **MAINTENANCE**

The installation and the control and/or recovery operations of fire extinguisher must be performed by qualified technician and in accordance to current regulations on the matter.

The technician will carry out annual inspection for check the internal pressure and after all other steps planned during the fire extinguisher useful life.

Any tampering or operation performed by unqualified technician, void the product warranty.

If possible, is recommended to place fire extinguisher in a dry place, protected from atmospheric agents.

For installation, use and maintenance follow as indicated in file : CSA_1_ENG

TECHNICAL SPECIFICATIONS

FIRE RATING	A IV B
EXTINGUISHING AGENT	Emme Waterfoam (2 % SC-6 orchidee + 98 % Water) (* Hyper-filtered water with an osmosis process)
PROPELLANT	2,5 Kg CO ₂
TEMPERATURE RANGE	+5°C / +60°C
NOMINAL CHARGE	100 Liters
FULL WEIGHT	~ 153 Kg
DIMENSIONS	Height 1350 +/- 10 mm ; Width 595 +/- 10 mm Depth 560 +/- 15 mm
DISCHARGE TIME	~ 85 seconds
CYLINDER PRESSURE TEST	PT 30 bar
CYLINDER VOLUME	134 L
SAFETY DEVICE	Set between 21 and 26 bar
CYLINDER MATERIAL	Stainless steel AISI 304
TREATMENT	Outside: Sandblast and powder painting Ral 3000

PACKAGING

(Note: the packaging quantities and measurements are indicative and can be subject at change)

STANDARD
Maximum nr. 2 pieces for pallet
Pallet dimensions 100x120x150(h) cm

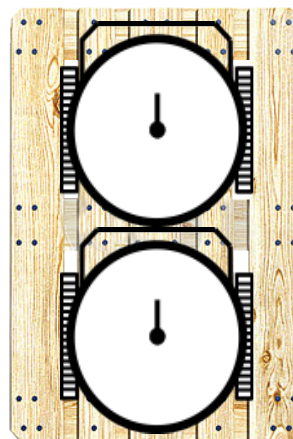

TRANSPORT DISPOSAL

Land transport : Exemption for the purposes of ADR disposal 594

Ship Transport : IMDG Code - UN 1044 class 2.2 Fire Extinguishers

File name	Type of document	Fire Extinguisher Model	Date	Rel.	Check	Rev.	Pag.
19118-52_Technical Manual	Technical Manual	19118-52	22/10/2024	M.R		2	2/3

COMPONENTS AND SPARE PARTS LIST

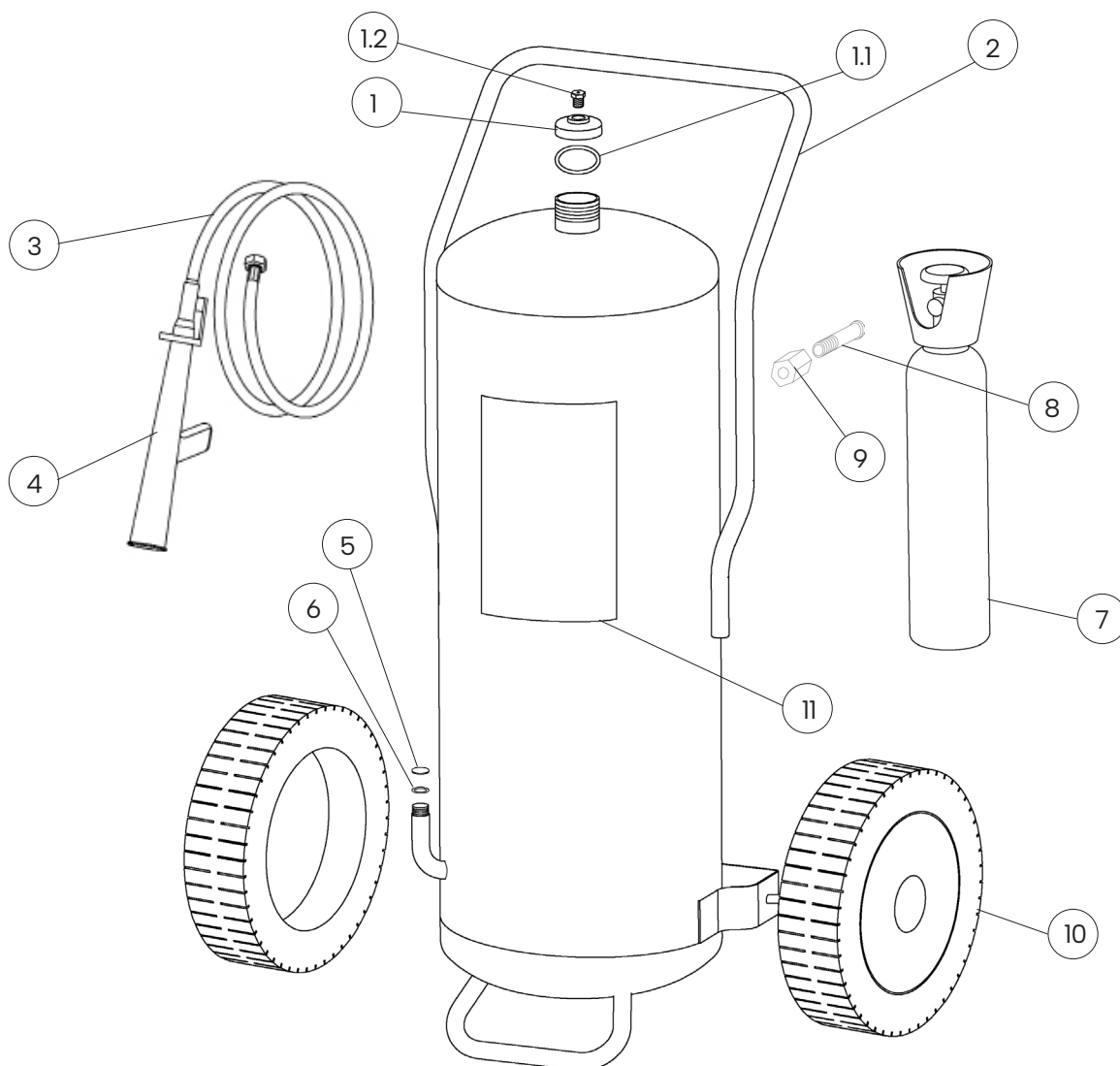

NUM.	DESCRIPTION	CODE
1	2" brass cap	18463
1.1	O-ring cap	n.a.
1.2	Safety device	n.a.
2	Cylinder	18324
3	Hose	18422-1
4	Dispensing lance (complete of ball valve with control lever and inox filter for foaming)	2181-3
5	Membrane	0262-4
6	Copper washer	2148-11

NUM.	DESCRIPTION	CODE
7	Complete pressurization cylinder, with 2,5 Kg CO2	n.a.
8	Fitting for cylinder with nitrogen cylinder	18489
9	Fitting for nitrogen cylinder with cylinder	18495
10	Wheel (diam. 400mm)	0125
	Thick washer	2148-10
	Cotter pin stop wheel	9443
11	Label	18343
	Additive for refill (1 Lt. concentrate) (To mix with water)	1470-1 (x2)

The spare part at number 1, includes already others components 1.1 and 1.2
 "n.a." mean that the component is not available as single spare part.

REPRODUCTION IS PROHIBITED

File name	Type of document	Fire Extinguisher Model	Date	Rele.	Check	Rev.	Pag.
19118-52_Technical Manual	Technical Manual	19118-52	22/10/2024	M.R		2	3/3