

Technical Manual



www.emme-italia.com

Via del Molino, 40 - 52010 Corsalone (AR) - Italy - info@emme-italia.com - Tel. +39.0575.511320
 Other branches in Italy : Milano - Padova - Roma - Palermo - Cagliari - P.IVA/ C.F. 11208251006 - R.E.A. AR-159122

21031-1 : Portable Fire Extinguisher, 3 Kg ABC Powder



- **CYLINDER**
In high-strength alloy steel, deep drawing, external powder painting Red Ral 3000.
- **EXTINGUISHING AGENT**
ABC Powder - MAP 20 %.
- **PROPELLANT**
Dehumidified air or nitrogen (N₂).
- **VALVE**
M. 30x1.5, lightweight aluminum alloy AA6061 body, levers with red painting Ral 3000.
- **USE**
A B C fire rating (solid materials, flammable liquids, flammable gas).

Note: image is for illustrative purpose only, the product purchased can has some difference

3 Kg powder fire extinguisher, temperature range from -30°C to +60°C, manufactured in accordance to **UNI EN 3-7 (D.M. 7.1.2005)**, approved Marine Equipment Directive **MED 2014/90/EU**, certified according to the directive for pressure equipment PED 2014/68/EU. Manufactured according at productions checks as agreed with **EN 3-10**. Quality Product certification guaranteed by Bureau Veritas Italia. Suitable for use on fire involving electrical voltages up to 1'000 V, at a minimum distance of 1 meter.

APPROVED/CERTIFIED FIRE EXTINGUISHER:

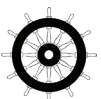

FIRE RATING :



13

113



REPRODUCTION IS PROHIBITED

File name	Type of document	Fire Extinguisher Model	Date	Rele.	Check	Rev.	Pag.
21031-1_Technical manual	Technical manual	21031-1	09/08/2024	M.R		2	1/3

21031-1 : Portable Fire Extinguisher, 3 Kg ABC Powder

- **INSTALLATION**
- **USE**
- **MAINTENANCE**

The installation and the control and/or recovery operations of fire extinguisher must be performed by qualified technician and in accordance to current regulations on the matter.

The technician will carry out annual inspection for check the internal pressure and after all other steps planned during the fire extinguisher useful life.

Any tampering or operation performed by unqualified technician, void the product warranty.

If possible, is recommended to place fire extinguisher in a dry place, protected from atmospheric agents.

For installation, use and maintenance follow as indicated in file : EPP_1_ENG

TECHNICAL SPECIFICATIONS

FIRE RATING	13 A 113 B C
EXTINGUISHING AGENT	ABC powder - MAP 20 % EPW 18462 (ABC Favorit Tertia - Rühl)
PROPELLANT	Dehumidified air or Nitrogen (N ₂), 15 Bar at 20°C
TEMPERATURE RANGE	-30°C / +60°C
NOMINAL CHARGE	3 Kg
FULL WEIGHT	~ 5,3 Kg
DIMENSIONS	Height (base - valve) 460 +/- 5 mm Diameter (cylinder) 130 +/- 2 mm
DISCHARGE TIME	~ 15 seconds
CYLINDER PRESSURE TEST	PT 27 bar
CYLINDER VOLUME	4,3 L
SAFETY DEVICE	Set between 20 and 26 bar
CYLINDER MATERIAL	Alloy steel
TREATMENT	Outside: Sandblast and powder painting, Ral 3000

PACKAGING

(Note: quantities and measurements are indicative and can be subject at changes)

STANDARD

Maximum nr. 126 pieces for pallet
(63 pieces for box, max 2 boxes for pallet)
Pallet dimensions 100x120x115(h) cm

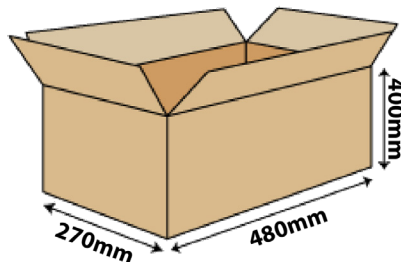

ON REQUEST: SINGLE PACKAGING

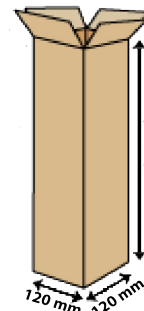

TRANSPORT DISPOSAL

Land transport : Exemption for the purposes of ADR disposal 594
Ship Transport : IMDG Code - UN 1044 class 2.2 Fire Extinguishers

File name	Type of document	Fire Extinguisher Model	Date	Rele.	Check	Rev.	Pag.
21031-1_Technical manual	Technical manual	21031-1	09/08/2024	M.R		2	2/3

21031-1 : Portable Fire Extinguisher, 3 Kg ABC Powder

COMPONENTS AND SPARE PARTS LIST

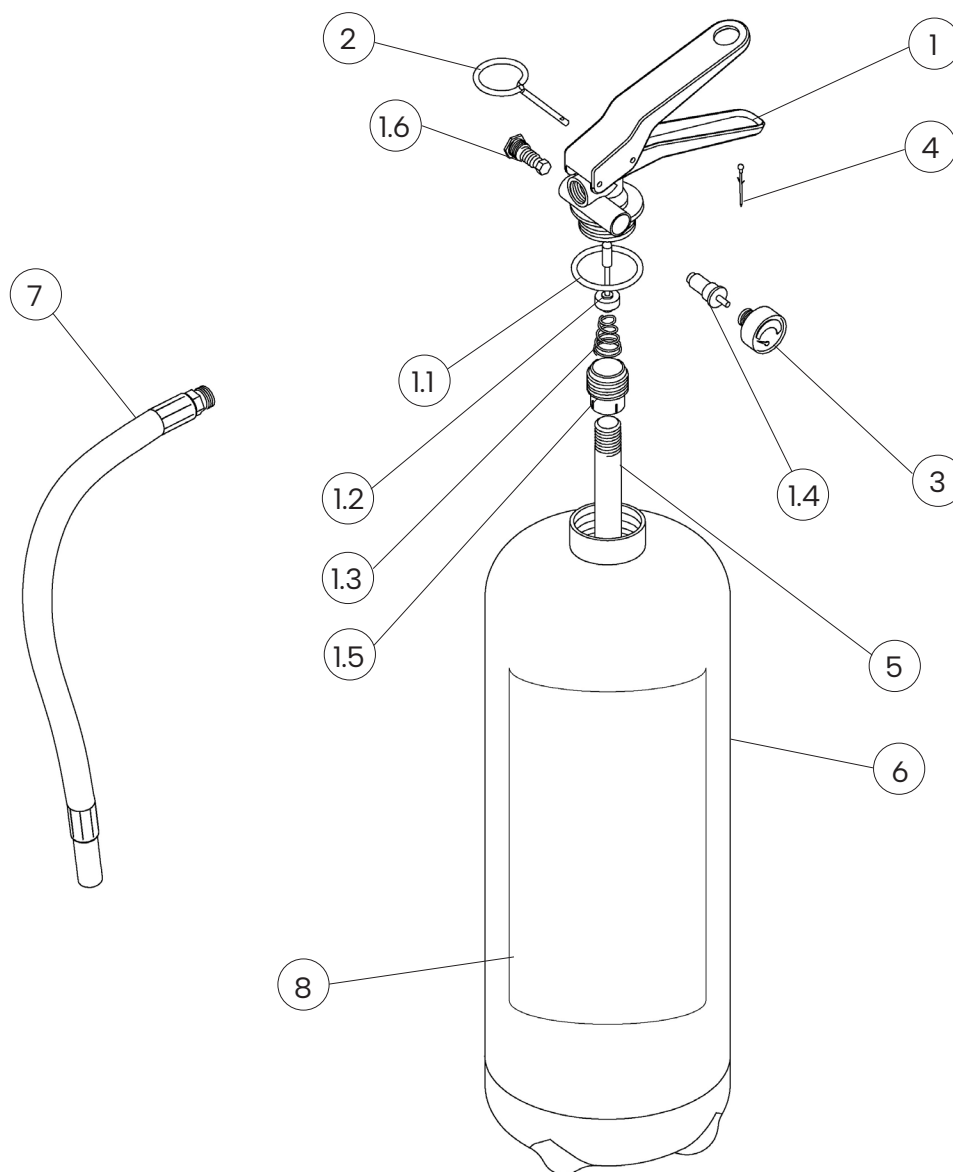

NUM.	DESCRIPTION	CODE
1	Valve M. 30x1.5	0212-9
1.1	O-ring valve	0201R
1.2	Valve stem	n.a.
1.3	Internal spring of the valve	n.a.
1.4	Test valve for pressure gauge	1163
1.5	Dip tube holder	n.a.
1.6	Safety device	n.a.
2	Safety pin	0282-1

NUM.	DESCRIPTION	CODE
3	Pressure gauge	0271-1
4	Safety pin seal	0285
5	PVC dip tube	0153
6	Cylinder	0103
7	Hose	0291
8	Label	0090-1
OPTIONAL	Iron marine bracket red painting	0315

The spare part at number 1 includes already all others components indicated from 1.1 to 1.6

"n.a." mean that the component is not available as single spare part

File name	Type of document	Fire Extinguisher Model	Date	Rele.	Check	Rev.	Pag.
21031-1_Technical manual	Technical manual	21031-1	09/08/2024	M.R		2	3/3