

Technical Manual



www.emme-italia.com

Via del Molino, 40 - 52010 Corsalone (AR) - Italy - info@emme-italia.com - Tel. +39.0575.511320
 Other branches in Italy : Milano - Padova - Roma - Palermo - Cagliari - P.IVA/C.F. 11208251006 - R.E.A. AR-159122

32063-1 : Portable Fire Extinguisher, 6 L Foam



Clip Detail



- **CYLINDER**
In high-strength alloy steel, deep drawing, with clip, external powder painting Red Ral 3000.
- **EXTINGUISHING AGENT**
Water-based foam.
- **PROPELLANT**
Auxiliary pressure.
Fire extinguisher pressurized at moment of use with 55g CO₂ cartridge.
- **VALVE**
M. 74x2, lightweight aluminum alloy, activation with percussion method.
- **USE**
A B fire rating
(solid materials, flammable liquids).
- **BRACKET**
Wall-mounted bracket for fire extinguisher with clip, red painting, in standard equipment

Note: image is for illustrative purpose only, the product purchased can has some difference

6 L foam fire extinguisher, auxiliary pressure, temperature range from +5°C to +60°C, manufactured in accordance to **UNI EN 3-7 (D.M. 7.1.2005)**, approved Marine Equipment Directive **MED 2014/90/EU** certified according to the directive for pressure equipment PED 2014/68/EU. Manufactured according at productions checks as agreed with **EN 3-10**. Quality Product certification guaranteed by Bureau Veritas Italia. Suitable for use on fire involving electrical voltages up to 1'000 V, at a minimum distance of 1 meter.

APPROVED/CERTIFIED FIRE EXTINGUISHER:



FIRE RATING :



34

233

File name	Type of document	Fire Extinguisher Model	Date	Rele.	Check	Rev.	Pag.
32063-1_Technical manual	technical manual	32063-1	24/04/2024	M.R		1	1/3

REPRODUCTION IS PROHIBITED

32063-1 : Portable Fire Extinguisher, 6 L Foam

• INSTALLATION

The installation and the control and/or recovery operations of fire extinguisher must be performed by qualified technician and in accordance to current regulations on the matter.

• USE

• MAINTENANCE

The technician will carry out **annual inspection** for check the internal pressure and after all other steps planned during the fire extinguisher useful life.

Any tampering or operation performed by unqualified technician, void the product warranty.

If possible, is recommended to place fire extinguisher in a dry place, protected from atmospheric agents.

For installation, use and maintenance follow as indicated in file : PSA_1_ENG

TECHNICAL SPECIFICATIONS

FIRE RATING	34 A 233 B
EXTINGUISHING AGENT	Foam EWAB15 (1,5 % SC-6 + 7 % Inilam AX + 91,5 % Water)
PROPELLANT	Cartridge with 55g CO ₂
TEMPERATURE RANGE	+5°C / +60°C
NOMINAL CHARGE	6 Liters
FULL WEIGHT	~ 10,6 Kg
DIMENSIONS	Height 510 (valve) / 525 (hose) +/- 5 mm Diameter (cylinder) 162 +/- 2 mm
DISCHARGE TIME	~ 35,2 seconds
VALVE TIGHTENING TORQUE	Minimum 40 Nm, Maximum 60 Nm
CYLINDER PRESSURE TEST	PT 30 bar
CYLINDER VOLUME	7,3 L.
SAFETY DEVICE	Set at 24 +/- 2 bar
CYLINDER MATERIAL	Alloy steel
TREATMENT	Outside: Sandblast and powder painting, Ral 3000 - Inside: Plastic coating

PACKAGING

(Note: quantities and measurements are indicative and can be subject at changes)

STANDARD

Maximum nr. 60 pieces for pallet
(single packaging)
Pallet dimensions 100x120 cm

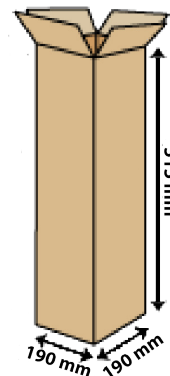

TRANSPORT

Land transport : Exemption for the purposes of ADR disposal 594

DISPOSAL

Ship Transport : IMDG Code - UN 1044 class 2.2 Fire Extinguishers

File name	Type of document	Fire Extinguisher Model	Date	Rele.	Check	Rev.	Pag.
32063-1_Technical manual	technical manual	32063-1	24/04/2024	M.R		1	2/3

32063-1 : Portable Fire Extinguisher, 6 L Foam

COMPONENTS AND SPARE PARTS LIST

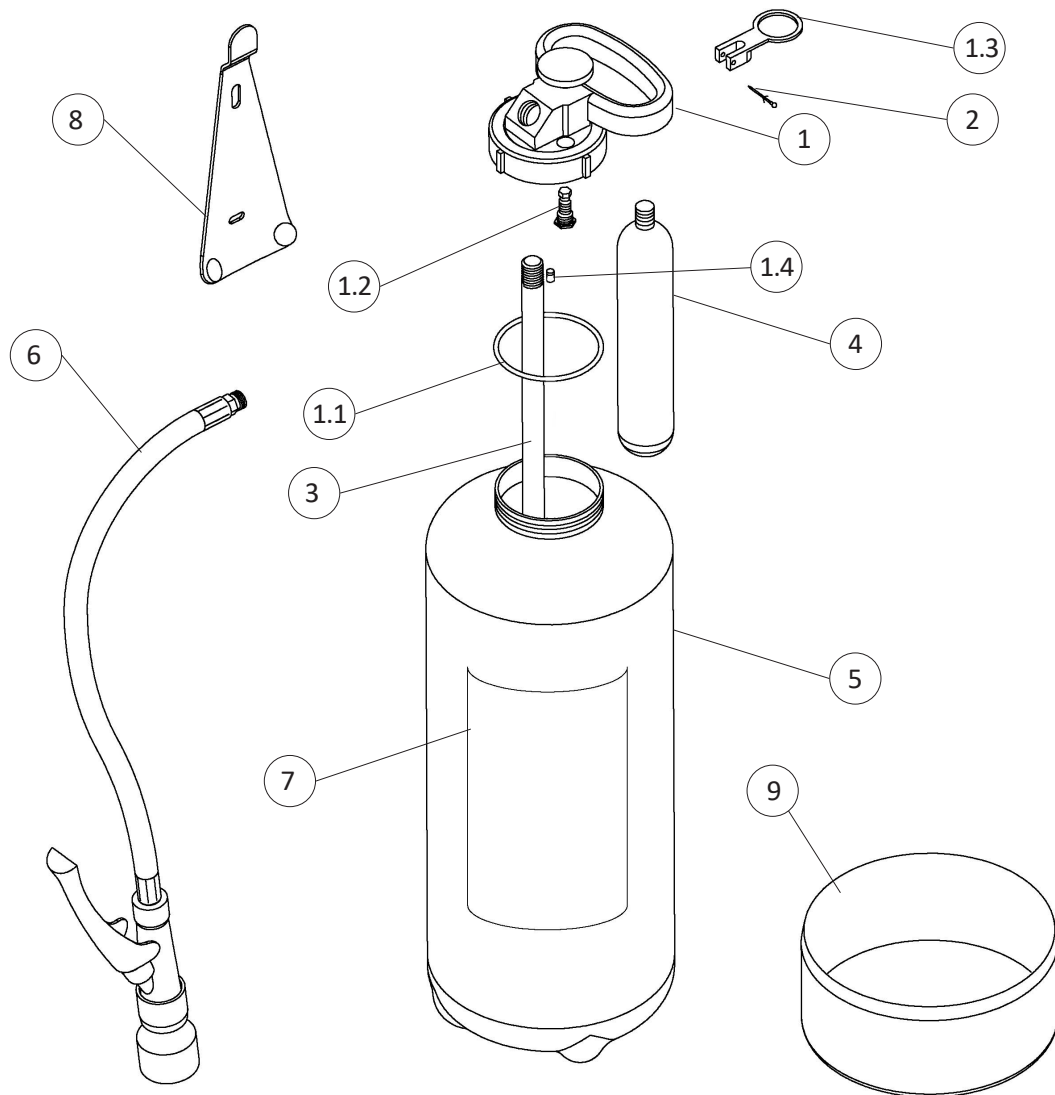

Table 1

NUM.	DESCRIZIONE	CODICE	NUM.	DESCRIZIONE	CODICE
1	Valve M. 74x2	3008-2	4	CO ₂ cartridge 55 gr.	3029-1
1.1	O-ring valve	0201-5	5	Cylinder	n.a.
1.2	Safety device	n.a.	6	Hose with dispensing pistol	3014-4
1.3	Safety pin	n.a.	7	Label 32063-1	2246
1.4	Pressurizer cap	n.a.	8	Wall-mounted bracket for fire extinguisher with clip	3036
2	Seal for safety pin	0285	9	Plastic bottom	n.a.
3	PVC dip tube	2179-1		Foam refill (6 L. bottle, ready to use)	2054-13

The spare part(valve) at number 1 includes already all others components indicated from 1.1 to 1.4
 "n.a" means that are not available as single spare part

File name	Type of document	Fire Extinguisher Model	Date	Rele.	Check	Rev.	Pag.
32063-1_Technical manual	technical manual	32063-1	24/04/2024	M.R		0	3/3